

Serial Number: 05217033

Operation and maintenance manual

STEAM STERILIZERS

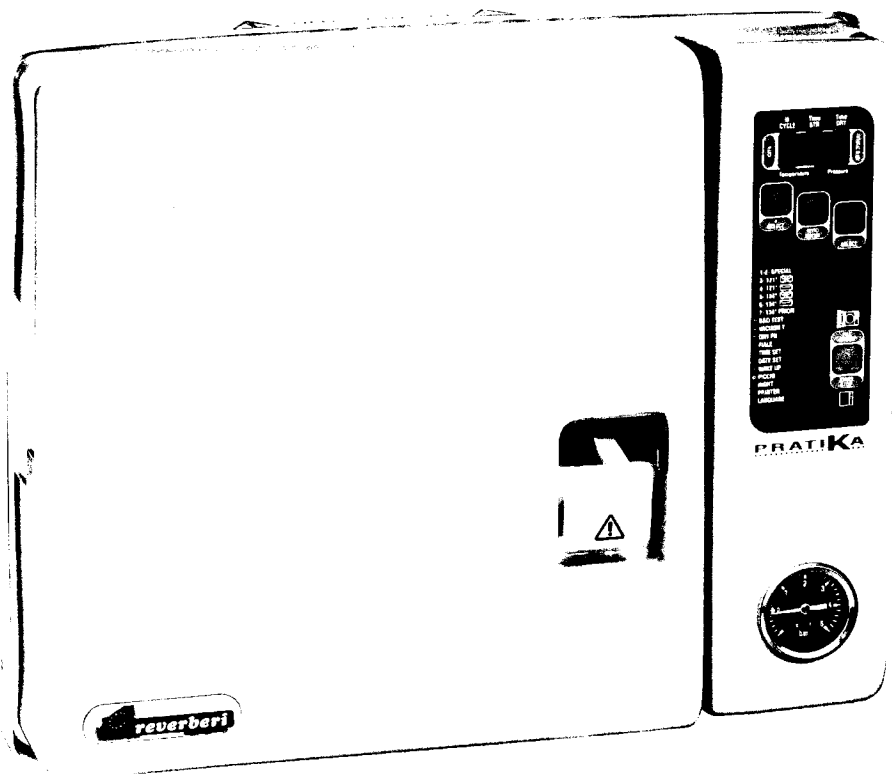

MODELS

PRATIKA B16-20

CE 0051

SILTEX(AUSTRALIA)Pty Ltd
18 Ardena Crt
East Bentleigh 3165 Vic.
Phone: (03) 9570 6222
Fax: (03) 9570 3644
E-mail: info@siltex.com.au
www.siltex.com.au

Table of Contents

Introduction	3
Technical specifications	4,5
General recommendations	6
Location of the controls	7
Remove sterilizer from packaging	8,9
Installation and preliminary inspections	10
Description of rear of sterilizer	11
Language settings	11
Table of cycles	11
Digital display information	12
General instructions for use	13
How to drain water from the external tank	13
Sterilizing table	14
Chamber Study	14
Trouble Shooting Messages	15
Operating messages	15
Printed messages	15
Maintenance	16
Daily routine maintenance	16
Weekly routine maintenance	16
Monthly routine maintenance	16
Electrical diagram	17
Electrical diagram	18
Pressure Conversion	19

For service ring 03 9570 6222

WARNING

- ❖ MAKE SURE BENCH IS LEVEL

- ❖ WAIT ONE MINUTE AFTER STERILIZER DISPLAY READS 80 °C BEFORE STARTING NEW CYCLE

- ❖ OPEN DOOR AFTER CYCLE



Introduction

The sterilizer described in this manual has been specially designed to sterilize most instruments used in dental and doctor's surgeries and other professional industries.

The machine can either operate at a temperature of 134°C and a pressure of 2.1 Bar or 121°C and a pressure of 1.1 Bar. These parameters are monitored and kept at constant levels by three mechanical and electronic devices that ensure an optimal sterilizing process along with total safety.

The operating cycles can be visually checked on a display installed on the control panel of the machine, or by means of an optional printer.

The machine will cycle fail with an error message if the sterilization cycle is unsatisfactory.

SYMBOLS AFFIXED TO THE MACHINE		WARNING: IDENTIFIES A HEAT SOURCE. A PART COULD BE DANGEROUSLY HOT
		WARNING: IDENTIFIES A GENERIC DANGER. THERE COULD BE A POTENTIALLY DANGEROUS CONDITION
		IDENTIFIES THE GROUND CONDUCTOR



Do not use the machine for purposes other than those for which it has been built.

Comply with the pertinent laws in force in the country of use if the machine is demolished.

To prevent the autoclave from being subjected to electrical disturbance, it is important to make sure that the earth resistance value is sufficient and well coordinated with the protections in your electrical system.

Technical Specifications

The **Pratika** sterilizers are designed and built in compliance with the operators' need for functionality, practical use and safety.

The **Pratika** is fully automatic. All functions are electronically assisted, so the operator knows what the sterilizer is doing at any given moment.

The **Pratika** has functional characteristics that make them unique, i.e.:

AUTOMATIC POWERING, the heating element maintains the chamber at a temperature of 80°C for up to 60 min., after which the sterilizer will automatically switch off if it is not used. The “night” program is to be selected for this function..

- **AUTOMATIC WATER FILLING** by means of an electric pump.
- Gradual heating to obtain a more accurate temperature and a better sterilizing process
- **AUTOMATIC AIR EXHAUST** to eliminate the air from inside the chamber at the beginning of the cycle, thus achieving the utmost steam saturation.
- **DRYING CYCLE** included: with thermodynamic system and vacuum pump
- **SAFETY THERMOSTAT** to prevent over temperature
- Electronic **DISPLAY** for all functions, with message display and printout.
- Press-moulded seamless 18/10 **STAINLESS STEEL CHAMBER**.
- **16 and 20 lt. CAPACITY** chamber.
- **SAFETY VALVE** to prevent overpressure
- After each cycle, the **Pratika** triggers an anti-condensation system, unless the door is opened within a few minutes.
- Tank for clean water

Description	Unit of measurement	Values
Power source voltage rating	V	240 V
Power source frequency	Hz	50
Machine power rating	W	2300
Boiler volume	mm	Ø 240 x 340 Ø 240 x 440 (B20)
Operating pressure	psi	16 - 30.5
Machine dimensions X, Y, Z	mm	Prof. 540 x Larg. 480 x H 530
Gross weight	Kg	50
Pack dimensions	mm	Prof. 680 x Larg. 560 x H 670
Operating temperatures	°C	+ 3°C + 35°C
Distance from walls	cm	8 - 10

X = depth

Y = width

Z = height

DATA AND SPECIFICATIONS OF THE PRESSURIZED VESSEL:

Max. operating pressure:	35 psi
Max. operating temperature:	160°C
Test pressure:	116 psi
Reference standards:	TRD 421
Volume of vessel:	16 and 20 litre

General Recommendations

3.1 Regulations for the Operator

- Do not approach the sterilizer with inflammable materials.
- Do not carry out repairs or maintenance work whilst the machine is operating or plugged into the electricity main or when parts of it are hot.
- Use the machine in a dry place
- Periodically inspect the power cable to make sure that it is in a good condition.
- If there are several persons in the place of work, remember to keep at a safe distance from the machine to prevent accidental contact with hot parts.
- Never ever operate the appliance unless the power cable is in a perfect condition and the structure undamaged.
- It is advisable to keep the door half-open with switch (8) turned off in “0” position, when the appliance is not in use.



Pay the utmost attention to those parts of the appliance that become hot during operation and that still remain hot after it has been switched off. Keep your face well away from the top part of the machine when the door is opened to prevent it from being scalded by steam. Keep about 50 cm. away from the machine when opening the door.

As specified in the technical specifications, these sterilizers operate at a pressure that can reach 33.4 psi at most. Do not use the sterilizer in an improper way and do not carry out maintenance operations while the sterilizing cycles are in progress. Remember that the pressure is shown by the pressure gauge installed on the front of the machine itself.

Wait at least 20 minutes after the appliance has been switched off, to allow the boiler to completely cool.

LOCATION OF THE CONTROLS

The PRATIKA feature an elegant casing treated with scratch-proof epoxy powder paint in the RAL 9010 COLOUR. No particular preparations are required to operate the machines. Just fit the plug into a 240 V power socket.

CONTROL PANEL:

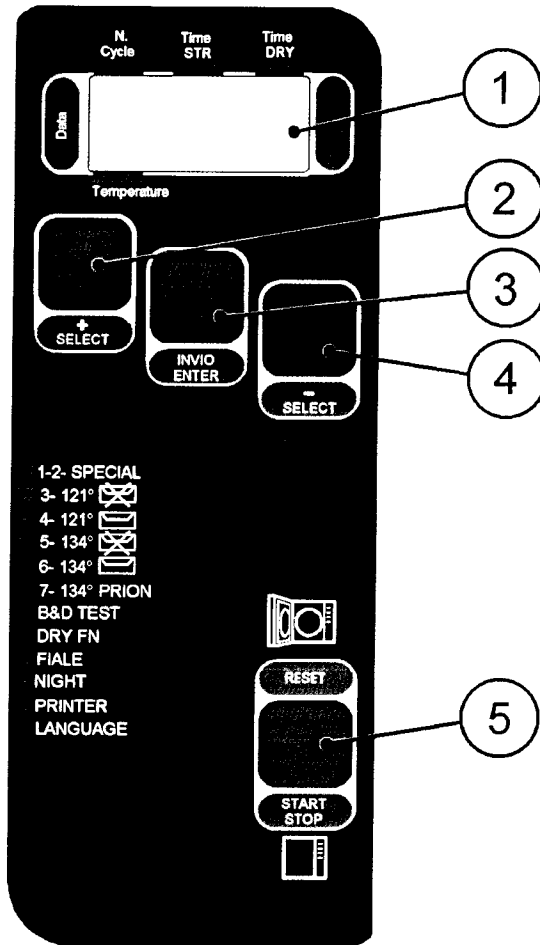

- 1 INFO DISPLAY
- 2 VALUE INCREASE / MENU'
- 3 OK / ENTER
- 4 VALUE DECREASE / MENU'
- 5 FILL WATER / START-STOP CYCLE
- 6 PRESSURE AND VACUUM GAUGE
- 7 PRINTER CONNECTING SOCKET
- 8 MAIN SWITCH
- 9 DOOR OPENING LEVER
- 10 WATER FILL UNION
- 11 BACTERIOLOGICAL FILTER
- 12 WATER DRAIN UNION

PRATIKA

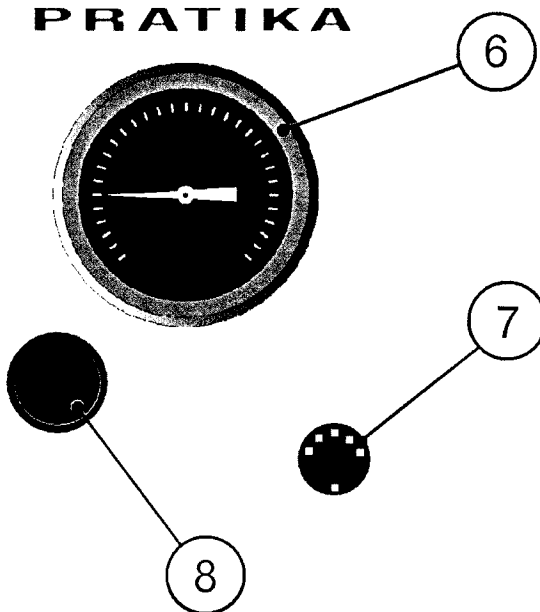

THE FOLLOWING ACCESSORIES ARE SUPPLIED:

1 TRAY HOLDER, 4 TRAYS, 1 TOOL TO TAKE OUT THE TRAYS AND ADJUST THE DOOR, 1 PIPE WITH FILTER FOR WATER FILLING, 1 WATER DRAIN PIPE, 1 TRANSPARENT Ø6 TUBE TO DRAIN WATER INTO THE CAN, 1 SPONGE, 1 INSTRUCTION MANUAL, 1 10 LITER CAN, 1 LIFTING HANDLE.

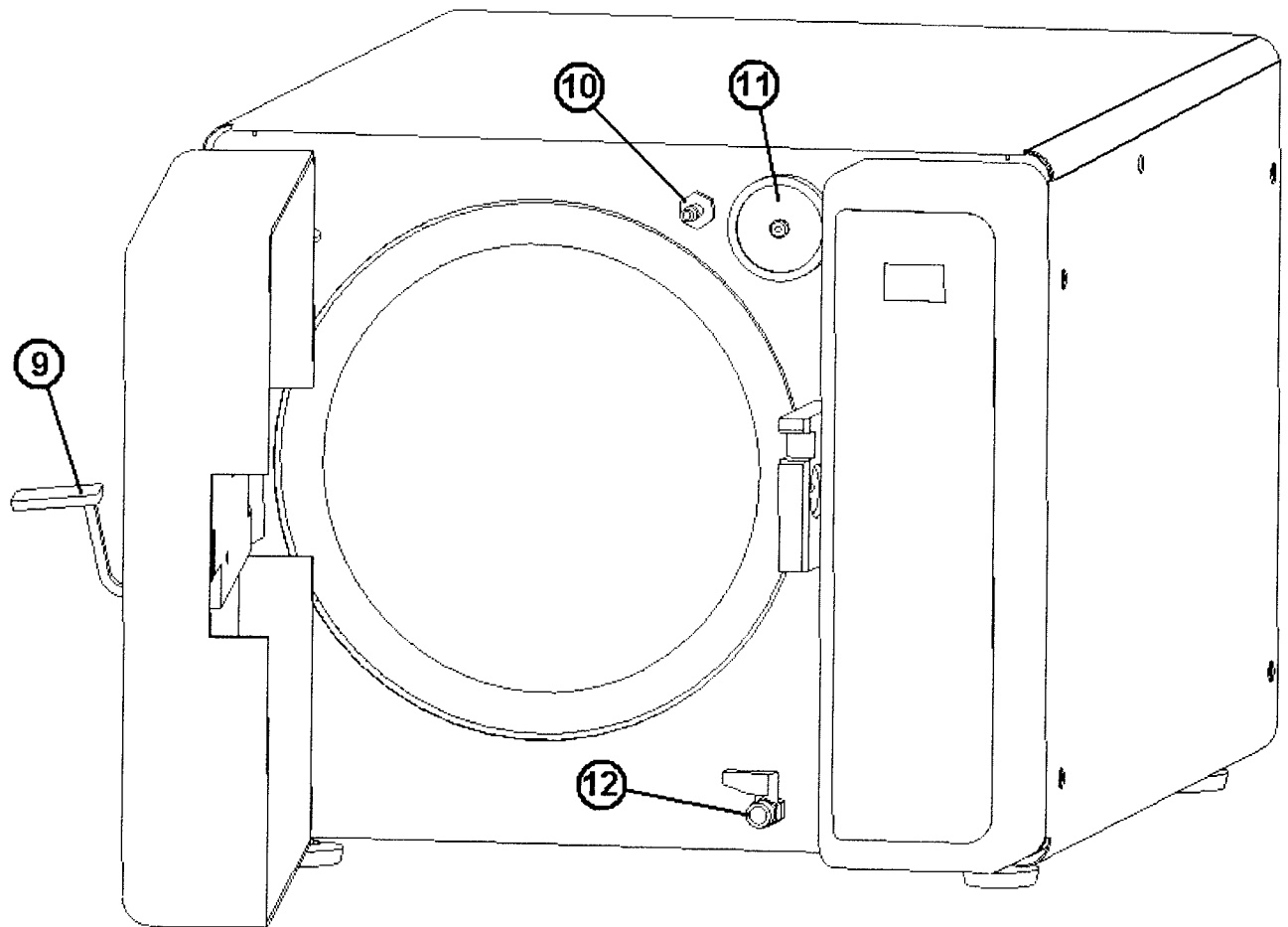

Starting and Setting Work

Removing the machine from the packing

The sterilizer is delivered in a cardboard box. Make sure that there are no dents and that the wrapping is in optimum condition.

The sterilizer must be stored in a dry place, sheltered from adverse weather conditions, at a temperature between +3°C and +35°C. The machine must be handled without jolting.

Open the pack without overturning it.

Lift the machine out of the box in a vertical direction using the 2 hooks supplied in the bag inside the pack. These should be inserted into the two holes at the sides of the casing (see drawing on page 9). Remove the bubble wrap from around the machine and make sure that the sterilizer is not damaged.

Keep the packing materials for as long as the machine remains in use, not just for the warranty period. This is because the sterilizer may need to be calibrated by a technician.

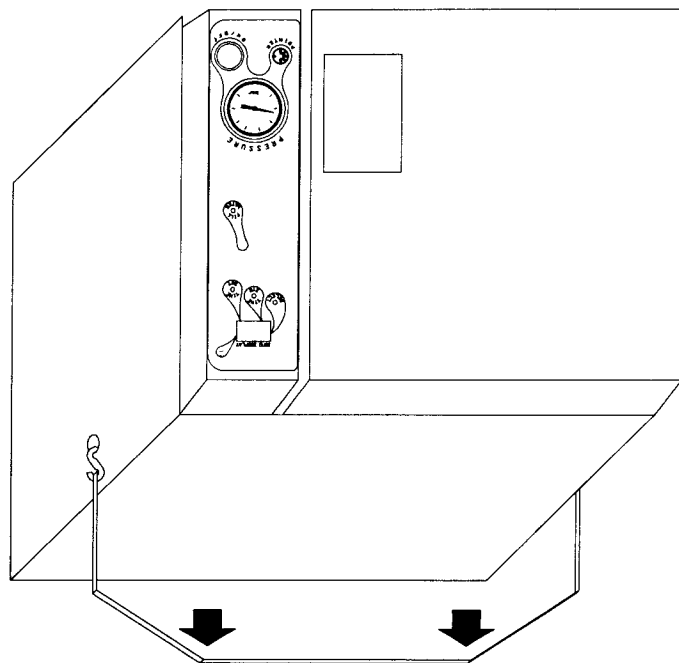
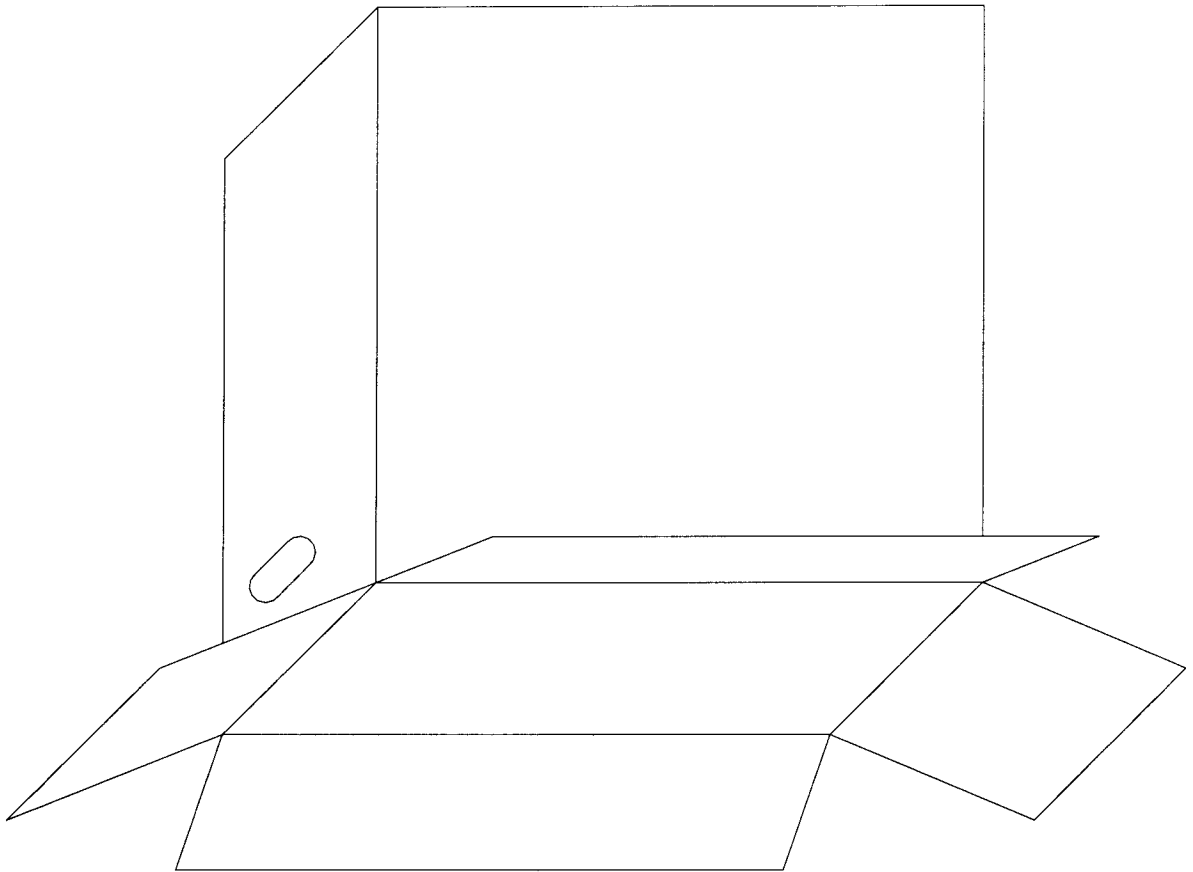

Installation and Preliminary Inspections

Install the sterilizer in a well ventilated place, well away from sinks, heat sources, grinders and from all other machines.

Fit the electric plug into a socket **WITH A CAPACITY OF AT LEAST 10 Amp AND EQUIPPED WITH AN EARTH CONNECTION**. Make sure that the mains voltage rating corresponds to the value indicated on the label at the rear of the machine (240 Volts).

BABY S must only be filled with **DISTILLED WATER** to ensure that the electrical and air-operated devices operate efficiently and are long lasting.



Never connect the plug of the machine to a reduction.

Use a bubble level to make sure that the surface on which the appliance is to be positioned is perfectly horizontal.

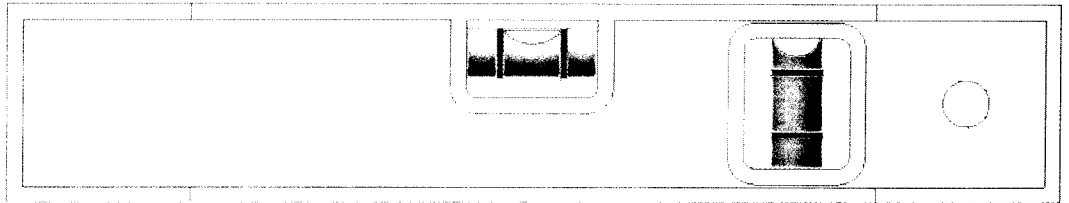

Fill out and send off the warranty form.

DESCRIPTION OF THE REAR PART

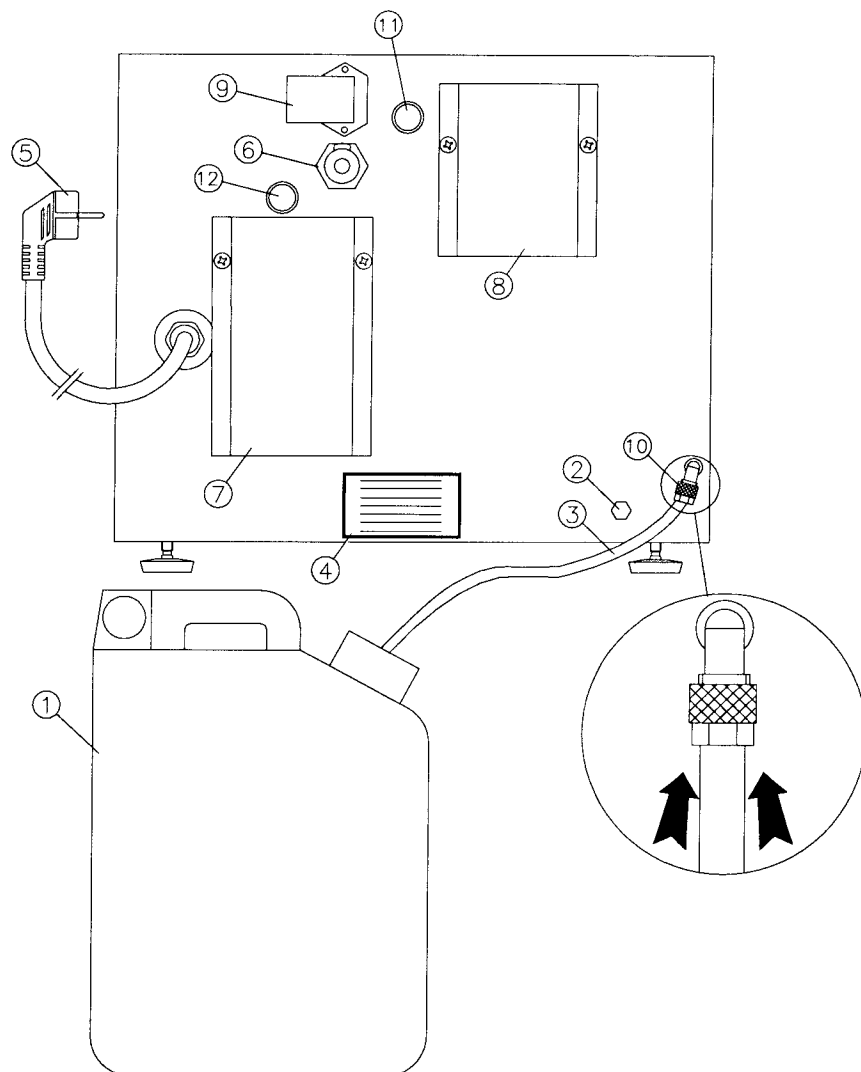

- 1) Can.
- 2) Generator drain.
- 3) Water drainpipe used for connecting to the can through "1". The same pipe can be used for draining into the sewage system.
- 4) Label showing the following data: Model, CE mark, power voltage and frequency, power input, serial number, year of manufacture, manufacturer's details.
- 5) Power cable with Shuko France plug.
- 6) Water connection point for treatment unit.
- 7) Power point for treatment unit.
- 8) Safety valve guard.
- 9) Electric connection point for treatment unit.
- 10) Fast fitting.
- 11) Safety dry
- 12) Safety boiler

LANGUAGE, DATE AND TIME SETTINGS:

With the door open and the machine on, scroll through the menu using key (2) or (4). Besides the sterilisation cycles, machine setting data can be displayed in succession (date, time, temperature in the chamber etc.). Enter the desired item and confirm with key (3). Change the figures with keys (2) and (4). Once desired changes have been made, always confirm with key (3).

TABLE OF CYCLES END SERVICES:

Nr. Progressiv	Cycle or service
1	CYCLE FREE
2	CYCLE FREE
3	CYCLE 121° UNWRAPPED
4	CYCLE 121° WRAPPED
5	CYCLE 134° UNWRAPPED
6	CYCLE 134° WRAPPED
7	CYCLE 134° PRIONE
B & D TEST	BOWIE & DICK TEST
VACUUM T	VACUUM TEST
DRY FN	CYCLE DRY
FIALE	CYCLE PHIALE
TIME SET	TIME
DATE SET	DATE
WAKE UP	WAKE UP
PICCHI	PRE-VACUUM
NIGHT	CYCLE NIGHT S/N
PRINTER	PRINT S/N
LANGUAGE	LANGUAGE GB/F/D/E/I

Digital Display Information

	3		1	5			5

3= Cycle number 15= Sterilization time 5= Dry time
121= Temperature of sterilization °C

	4		2	0		1	5

4= Cycle number 20= Sterilization time 15= Dry time
121= Temperature of sterilization °C

	5			4			5

5= Cycle number 4= Sterilization time 5= Dry time
134= Temperature of sterilization °C

	6		1	0		1	5

6= Cycle number 10= Sterilization time 15= Dry time
134= Temperature of sterilization °C

	7		1	8		2	0

7= Cycle number 15= Sterilization time 5= Dry time
134= Temperature of sterilization °C

B	&	D		T	E	S	T

BOWIE & DICK TEST not for instruments
134= Temperature of sterilization °C

V	A	C	U	U	M		T

VACUUM TEST

	D	R	Y		F	N	

ADDITIONAL DRY
110= Temperature of sterilization °C

	B	O	T	T	L	E	

PHIAL CYCLE
54= Temperature of sterilization °C for 48 hour

T	I	M	E		S	E	T

TIME SET

D	A	T	E		S	E	T

DATE SET

W	A	K	E		U	P	

DELAYED STARTING for next 24 h

	P	E	A	K	S		

Number of vacuum peaks (max. 3). Only for cycle 1 or 2

N	I	G	H	T		F	N
Y	E	S	/	N	O		

NIGHT CYCLE
YES= Active NO= Inactive

P	R	I	N	T	E	R	
Y	E	S	/	N	O		

PRINTER SELECTION
YES= Active NO= Inactive

L	A	N	G	U	A	G	E

LANGUAGE SELECTION

N	.	C	Y	C	L	E	S

NUMBER OF CYCLES

L	I	Q	U	I	D		
Y	E	S	/	N	O		

CYCLE FOR LIQUID STERILIZATION
YES= Active NO= Inactive

General Instructions For Use

OPEN DOOR WITH SWITCH (9) TURNED.

- Remove the tray holder pack from the chamber.
- Switch on the master switch (8).
- The display unit will indicate lack of water with the message NO WATER IN TANK.
- Connect the pipe to the pipe connection (10) and place the other end of the pipe in the distilled-water can.

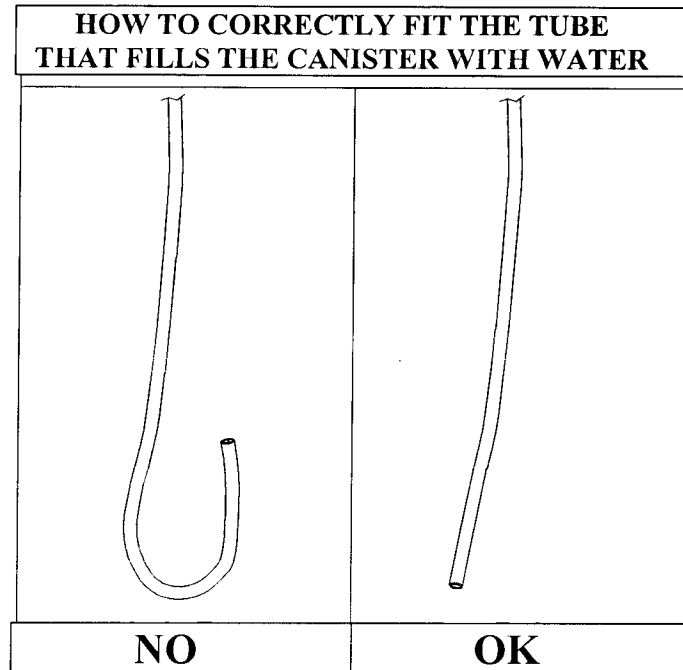

- Press the button (5) to start the water supply pump, which will stop automatically when the water tank has reached maximum level.
- The display unit will show the number of the previously performed cycle.
- If a different cycle to that shown on the display unit (1) is to be performed, press button (2) or (4) to scroll the menu.
- For a customised ("special") cycle, select cycles number one or two. Once a "special" cycle has been selected, press key (3) to change the settings made. It is possible to change the sterilisation time, the drying time, the sterilisation temperature and the minimum vacuum value of the vacuum peaks. The settings can be changed using keys (2) and (4) before confirming with key (3). As regards the number of pre-vacuum peaks, enter from the main menu at the PEAKS item and set the desired figure, changing the setting with keys (2) and (3) and confirming with key (3). The number of peaks only concerns cycles one and two ("special").
- Refer to the cycle table on page 15.
- After terminating the settings on the display unit (1), introduce the tray holder into the chamber with the load to be sterilised.
- To start the cycle, close the door with the handle (9).
- Press key (5) to start the cycle.
- The end of the cycle is indicated by a message on the display unit (1).

How to drain the water from the tanks

- Check the tank level (used water) before each cycle.
- In case the level is nearly full, please behave as follows:
- Unscrew the plug of the tank.
- Empty the tank in drainage and rinse with care.
- Screw the plug of the tank (make attention to not twist the discharge tube and be sure that the tank is in stable position).

Sterilizing Table

CYCLES FREE	STERILIZING TIME (Min.)	DRYING TIME (Min.)
1	*	*
2	*	*

CYCLES AT 121°	STERILIZING TIME (Min.)	DRYING TIME (Min.)
3 UNWRAPPED	15	5
4 WRAPPED	20	15

CYCLES AT 134°	STERILIZING TIME (Min.)	DRYING TIME (Min.)
5 UNWRAPPED	4	5
6 WRAPPED	10	15
7 PRIONE	18	20

TEST	STERILIZING TIME (Min.)	DRYING TIME (Min.)
BOWIE & DICK*	3.5	2
Vacuum**	15 (Total length of test)	

CYCLE PHIAL	STERILIZING TIME (Min.)	DRYING TIME (Min.)
54°	48h (Total length of test)	

Chamber Study

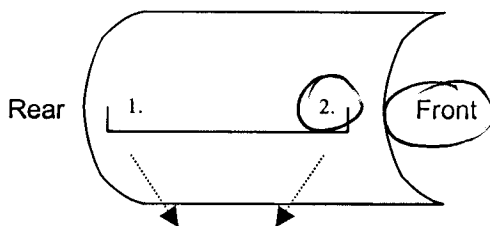

Thermocouple No: 020402049 (Offset T1 $\pm 0.0^\circ\text{C}$ T2 $\pm 0.1^\circ\text{C}$)

Calibration No: 041105

Temperature Tolerance 135 \pm 1°C 122 \pm 1°C

1. 135.8 2. 135.7

Cold spot as determined by chamber study (Please circle)

Date:

Sig:

Trouble Shooting Messages

MESSAGE	ERROR TYPE	REMEDY
FAILED	Cycle not terminated	Check presence of any leaks in the hydraulic circuit, in the door seal (adjustment), solenoid valve N.O.
NO POWER	No mains power	Fit the machine plug in a single socket that complies with standards and is without adapters or extensions. Change the fuse and check the causes. Make sure the master switch (8) is not turned off with closed door.
NO WATER IN TANK	Not enough clean water in load tank	Fill up
BOILER	Boiler level error	Steam generator level probe cleaning
HIGH	High temperature	Check generator solenoid valve and temperature probe cable (PT100)
LOW	Low temperature	Check solenoid valve, thermostat and heating element of generator. Clean the generator probe.
VACUUM	Vacuum error	Check the vacuum pump and the relevant solenoid valve. Check the vacuum values on the display unit and on the pressure gauge.
MAX TEMP.	High boiler pressure	Check the temperature probe (PT100) and cable or detached cable.
PRESS. ERR.	Pressure error	Perform the vacuum test and check for any leaks. Check for any transducer malfunctions.
U.FULL	Used water tank full.	In case of connection, empty the tank

To reset the machine, turn the switch (8) off and on.

2 Operating messages

MESSAGE	OPERATION IN PROGRESS
Vac. test	Check hydraulic circuit for leaks
Phials	Pre-sterilised phial culture cycle
Print.	Start print
No cycle	Maintenance of instrumental drying
Hr. set	Time set
Start time	Start delayed up to 24 hours
Peaks	Vacuum, pressurisation, release
no. cycles	No. of cycle performed by machine
Italian	Current language (set)
End	Cycle finished
Liquid	Liquid sterilisation (gradual drain)

8.3 Printed Messages

MESSAGE	OPERATION
Ster. time	Sterilisation time
Type of cycle	Cycle type
Ster. time	Sterilisation time
Min.	Cycle min.
Sec.	Cycle sec.
Hrs	Cycle hrs.
C	Degrees centigrade
Sterilisation	Sterilisation phase
Pressurisation	Steam injection
Drying	Drying stage
End	End of cycle
Total time	Total cycle time
Test	Test cycle
Release	Steam release
Stopped	Cycle stopped by operator

Maintenance

Caution

- Only carry out cleaning and maintenance on sterilizer when chamber has sufficiently cooled.
- During long periods of disuse, empty internal and external water tanks, and leave door ajar
- Do not use inflammable liquids for cleaning sterilizer

Daily Routine Maintenance

Wipe out chamber and door seal using supplied sponge. Use only distilled or demineralised water for cleaning.

Check the water level in the dump tank – drain if necessary. Wash out the dump tank under running water.

Weekly Routine Maintenance

Following daily maintenance, clean the scaling (mineral deposits) from the chamber using the rough side of the supplied sponge, then wipe out the chamber to remove any loosened debris.

Monthly Routine Maintenance

Clean the outside casing of the sterilizer with a slightly damp sponge, including the door casing.

Empty out the internal water tank via the tap behind the front door cover and flush through with warm tap water. Refill internal tank with distilled or demineralised water.

ELECTRICAL SYSTEM PRATIKA:

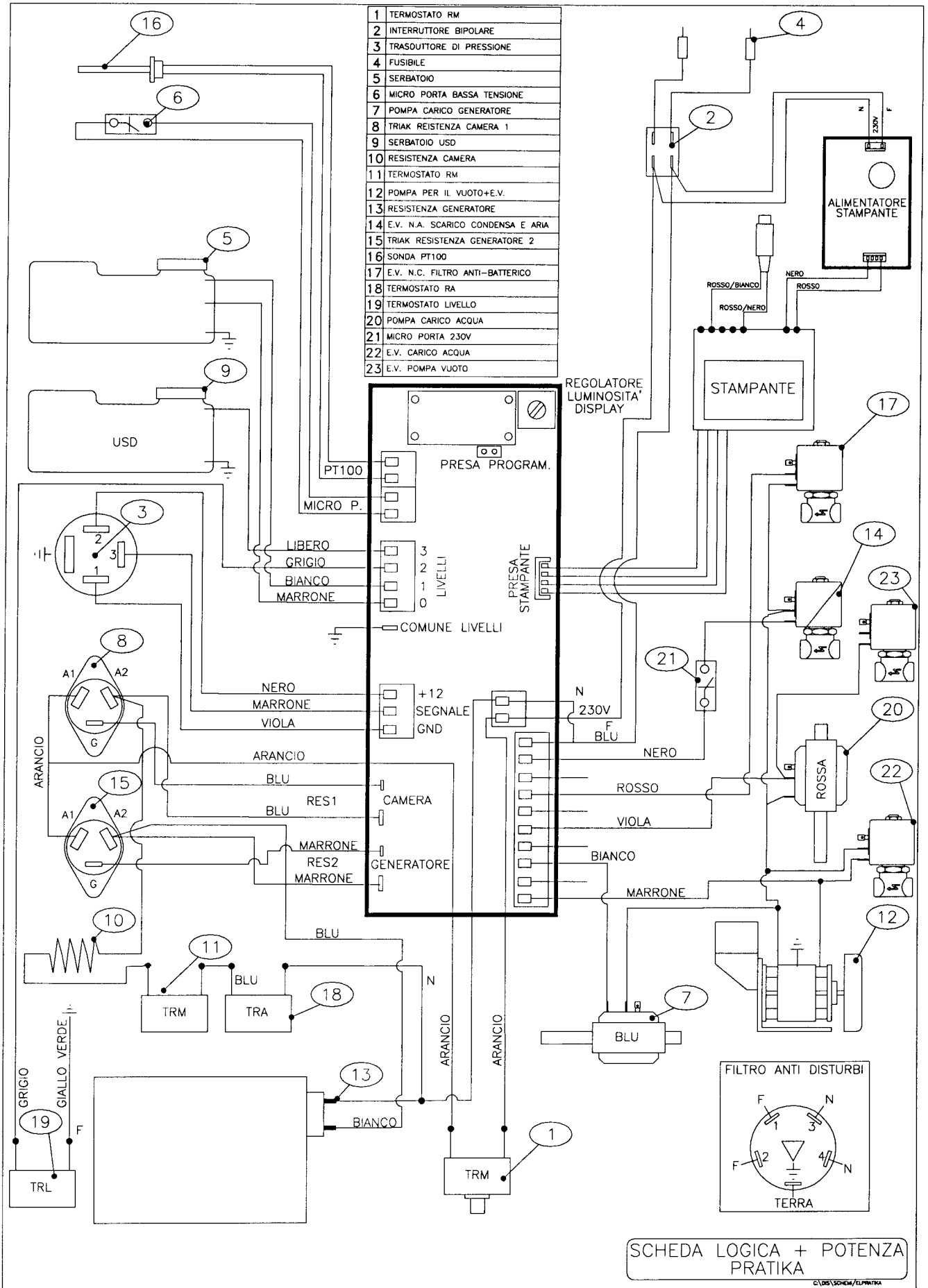

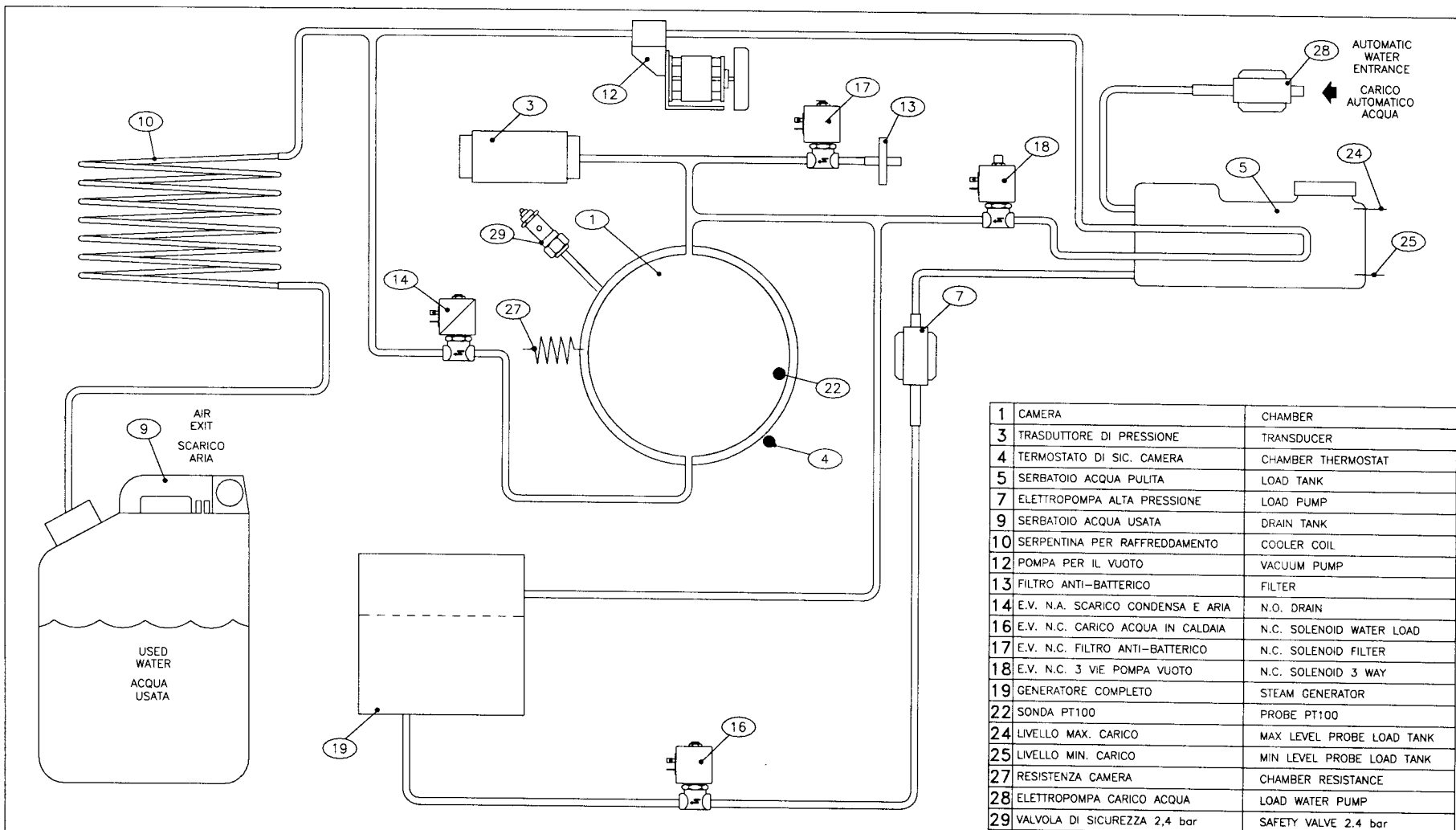

1	CAMERA	CHAMBER
3	TRASDUTTORE DI PRESSIONE	TRANSDUCER
4	TERMOSTATO DI SIC. CAMERA	CHAMBER THERMOSTAT
5	SERBATOIO ACQUA PULITA	LOAD TANK
7	ELETTROPOMPA ALTA PRESSIONE	LOAD PUMP
9	SERBATOIO ACQUA USATA	DRAIN TANK
10	SERPENTINA PER RAFFREDDAMENTO	COOLER COIL
12	POMPA PER IL VUOTO	VACUUM PUMP
13	FILTRO ANTI-BATTERICO	FILTER
14	E.V. N.A. SCARICO CONDENZA E ARIA	N.O. DRAIN
16	E.V. N.C. CARICO ACQUA IN CALDAIA	N.C. SOLENOID WATER LOAD
17	E.V. N.C. FILTRO ANTI-BATTERICO	N.C. SOLENOID FILTER
18	E.V. N.C. 3 VIE POMPA VUOTO	N.C. SOLENOID 3 WAY
19	GENERATORE COMPLETO	STEAM GENERATOR
22	SONDA PT100	PROBE PT100
24	LIVELLO MAX. CARICO	MAX LEVEL PROBE LOAD TANK
25	LIVELLO MIN. CARICO	MIN LEVEL PROBE LOAD TANK
27	RESISTENZA CAMERA	CHAMBER RESISTANCE
28	ELETTROPOMPA CARICO ACQUA	LOAD WATER PUMP
29	VALVOLA DI SICUREZZA 2,4 bar	SAFETY VALVE 2.4 bar

SETTORE DENTALE

reverberi

S.R.L.

v. Don L. Sturzo, 6 42020 BARCO (RE)
Tel. 0522/875159 Fax. 0522/875579

**IMPIANTO IDRAULICO
PRATIKA B & S**

PRESSURE CONVERSION

Sterilization Temperature	Absolute Pressure (kPa)	Psi	Absolute Pressure (millibars)	Pressure (Bar)
110	43.26	6.28	1430	0.43
111	48.15	6.99	1480	0.48
112	53.15	7.71	1530	0.53
113	58.31	8.46	1530	0.58
114	63.62	9.23	1630	0.63
115	69.05	10.02	1690	0.69
116	74.64	10.83	1740	0.74
117	80.38	11.67	1800	0.80
118	86.27	12.582	1860	0.86
119	92.33	13.40	1920	0.92
120	98.53	14.30	1980	0.98
121	104.89	15.22	2040	1.04
122	111.46	16.18	2110	1.11
123	118.16	17.15	2180	1.18
124	125.02	18.15	2250	1.25
125	132.10	19.17	2320	1.32
126	139.33	20.22	2390	1.39
127	146.76	21.30	2460	1.46
128	154.36	22.40	2540	1.54
129	162.16	23.54	2620	1.62
130	170.13	24.70	2700	1.70
131	178.30	25.88	2780	1.78
132	186.70	27.10	2860	1.86
133	195.26	28.34	2950	1.95
134	204.07	29.62	3040	2.04
135	212.94	30.91	3120	2.12
136	222.15	32.24	3220	2.22
137	231.73	33.63	3310	2.31
138	241.38	35.03	3410	2.41
139	251.28	36.47	3510	2.51
140	261.42	37.94	3610	2.61